

- SuperATV does not recommend keeping Windshield installed while transporting on an open air trailer. Remove or secure with straps.
- This item is not returnable if the protective film has been removed.
- Test fit to the cage to confirm fitment before removing film.

Item	Description
A	Upper Windshield



(kit contents continue on following page)

Windshield Cleaning:

- Do not use Rain-X®, Plexus® or any other protector, wax, or polish.
 - Do not use window cleaning fluids (Windex, 409, etc) or any solvents (gasoline, denatured alcohol, acetone, etc).
 - Never use abrasive cleaners, abrasive pads, or gritty cloths.
 - Do not use a windshield wiper blade or install a motorized windshield wiper
 - Never use razor blades, scrapers, squeegees, brushes, etc.
1. Thoroughly rinse Windshield to float off dirt and mud.
 2. Using a soft cloth, or microfiber cloth, clean Windshield with warm water and a gentle detergent. Baby shampoo, rubbing alcohol, or hand washing soap can also be used.
 3. To prevent water spots, use a chamois to blot Windshield dry.

Need help with your installation?



sales@superatv.com



www.superatv.com



1-855-743-3427



8:00am - 8:00pm EST M-Th
 8:00am - 7:00pm EST Friday
 9:00am - 2:00pm EST Saturday

Read instructions and view illustrations before beginning.

Thank You

For Choosing



Item	Description
B	Lower Windshield

(kit contents continued)

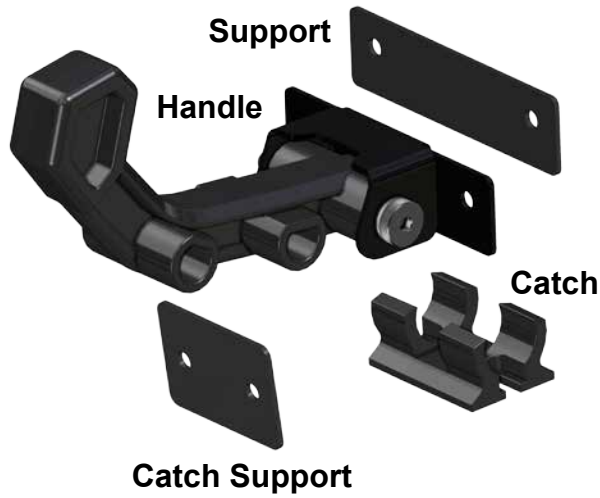
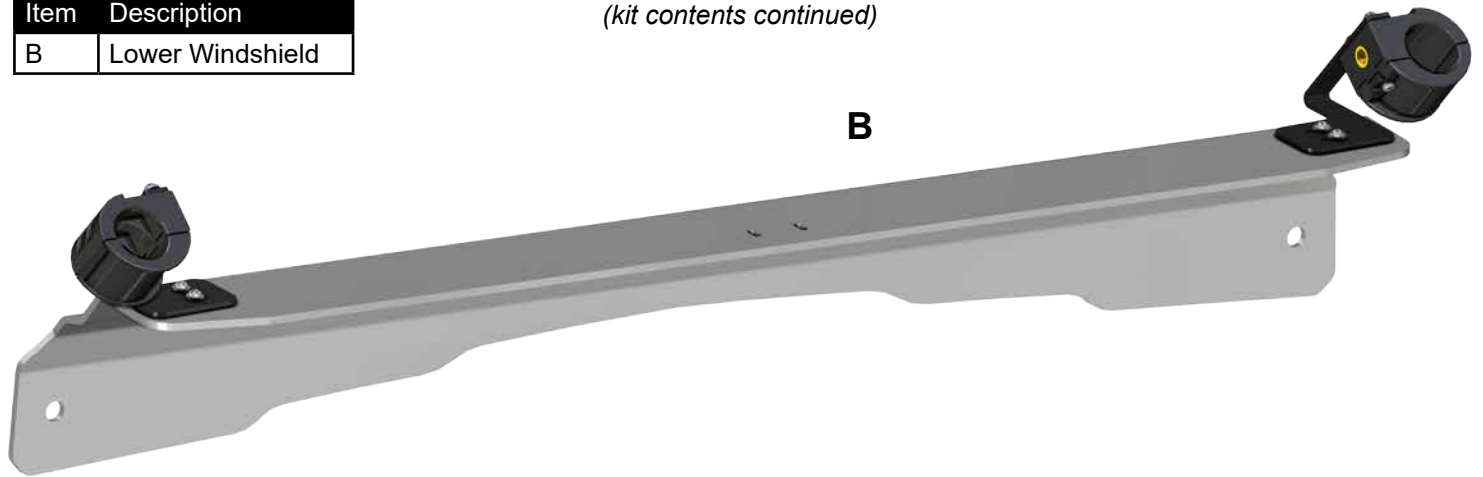

When assembling, **do not tighten hardware completely.**

2x  M8-1.25 Nylock Nut

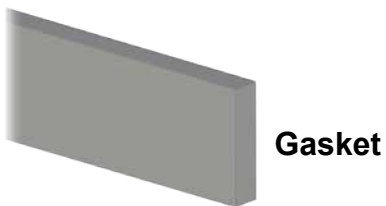

Gasket

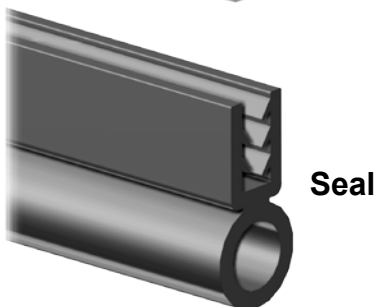

Seal

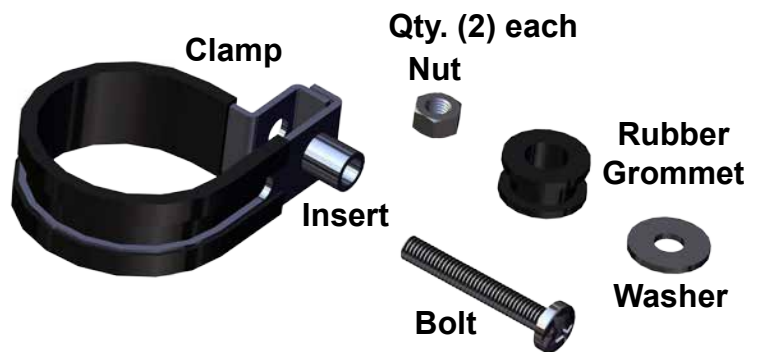

Qty. (2) each

Nut

Rubber Grommet

Washer

Clamp

Insert

Bolt

- Install provided Seal to Lower Windshield (B).

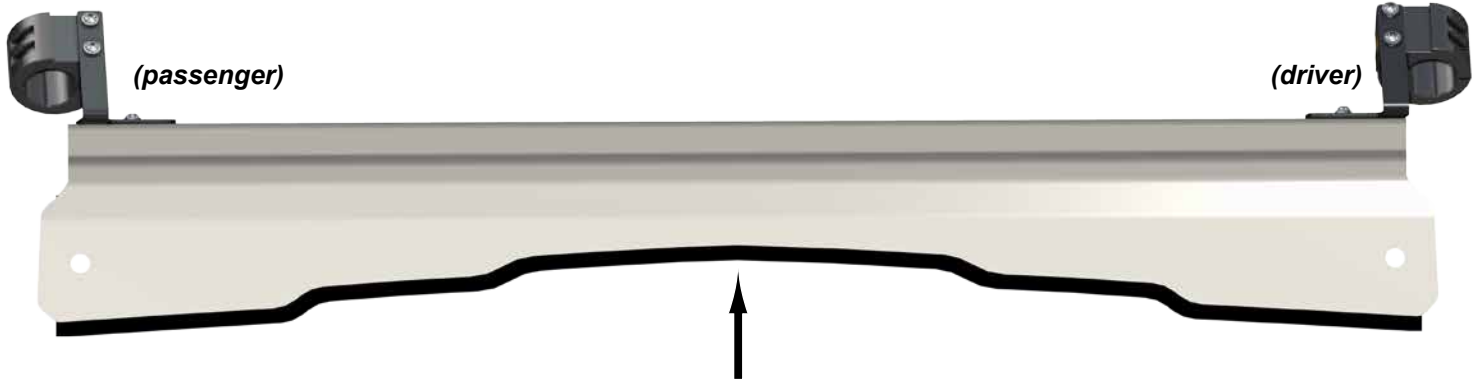

To ease installation, soak Seal in hot water before cutting or installing to increase flexibility.

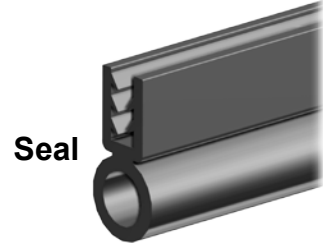

- Install Catch and Catch Support to Lower Windshield (B).
- Hardware included with Catch.

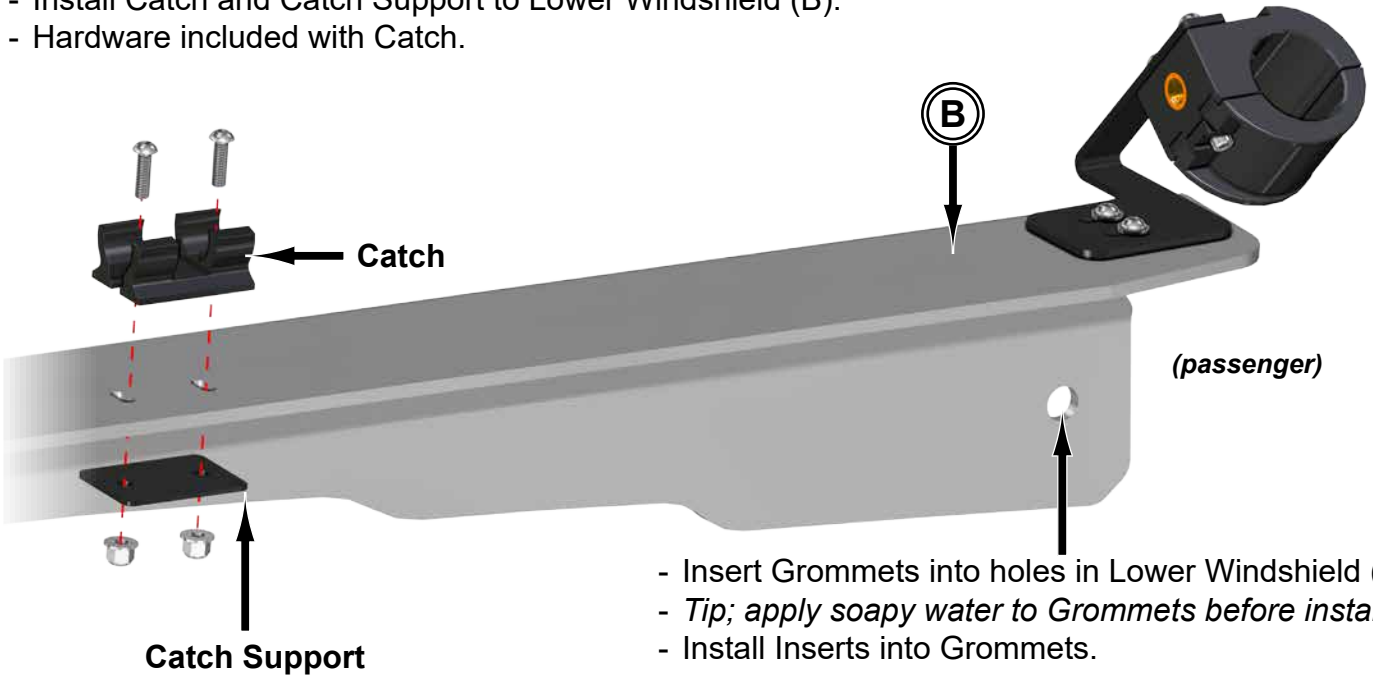

- Insert Grommets into holes in Lower Windshield (B).
- *Tip; apply soapy water to Grommets before installing.*
- Install Inserts into Grommets.

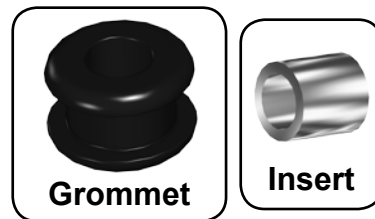

- Place Lower Windshield (B) assembly onto Cage and secure with Clamps; hardware included with Clamps.
- Install provided Gasket to Lower Windshield (B).

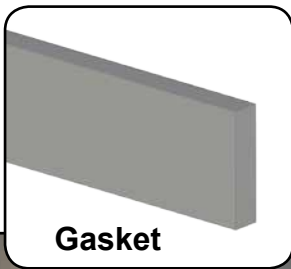
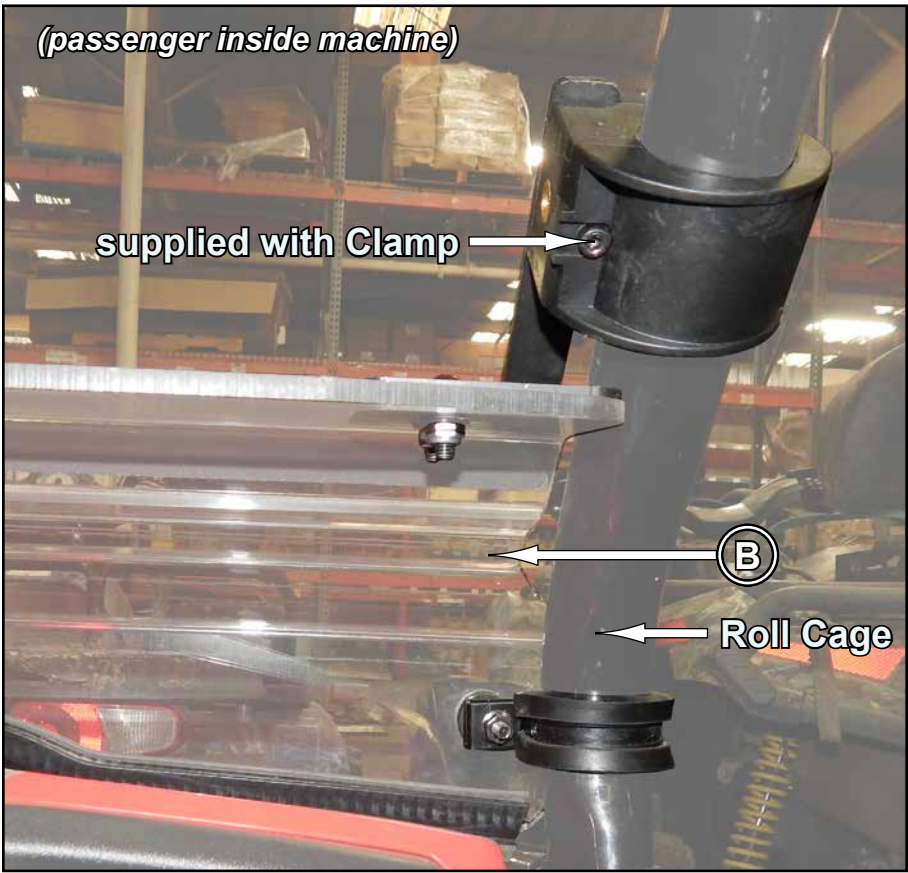

- Install Handle and Support to Upper Windshield (A).
- Hardware included with Handle.



Extra hands will make Upper Windshield (A) installation easier.

- Place Upper Windshield assembly onto Cage and secure Clamps; hardware included with Clamps.
- Engage Latch and align Windshield assembly to machine making sure that Seal, on Lower Windshield (B), is in contact with Hood.



- Place Upper Windshield (A) in open position and secure Gas Struts to Pivot Blocks with hardware shown.

